



General Specifications:

Composition:

6063-T5 Aluminum Extrusions

Coating:

Interpon Powder Coat AAMA 2604

Finish:

Wood Grain Sublimation AAMA 2604

Fire:

ASTM E84, CAN/ULC S102, CAN/ULC S114

Wind:

TAS 201, 202 & 203 (Large Missile)
 ASTM E8 (Tensile Strength)

Warranty:

15 Years

Benefits:

100% Recyclable
 Made in USA

Features:

Assembly:

Interlocking Cladding/Soffit Panels and Trims

Orientations:

Horizontal, Vertical, Diagonal

Sizes:

4", 6", 8" and 12"
 20' Standard Production Lengths

Design:

Adjustable 3/8" Reveal
 32" Max Fastening Span

Colors:

35+ Woodgrain Colors, 10+ Solid Colors
 Custom color creation + color matching available

Installation:







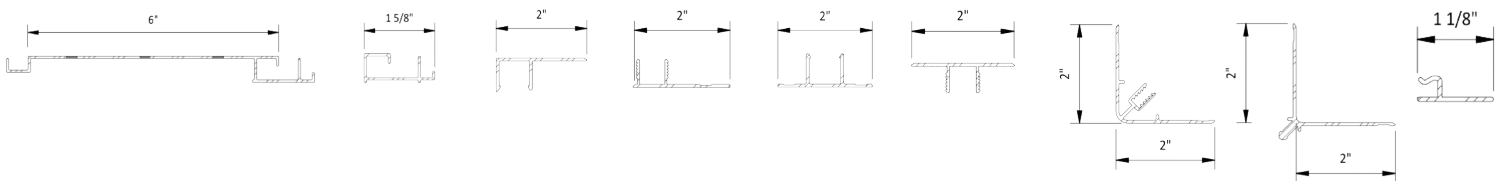
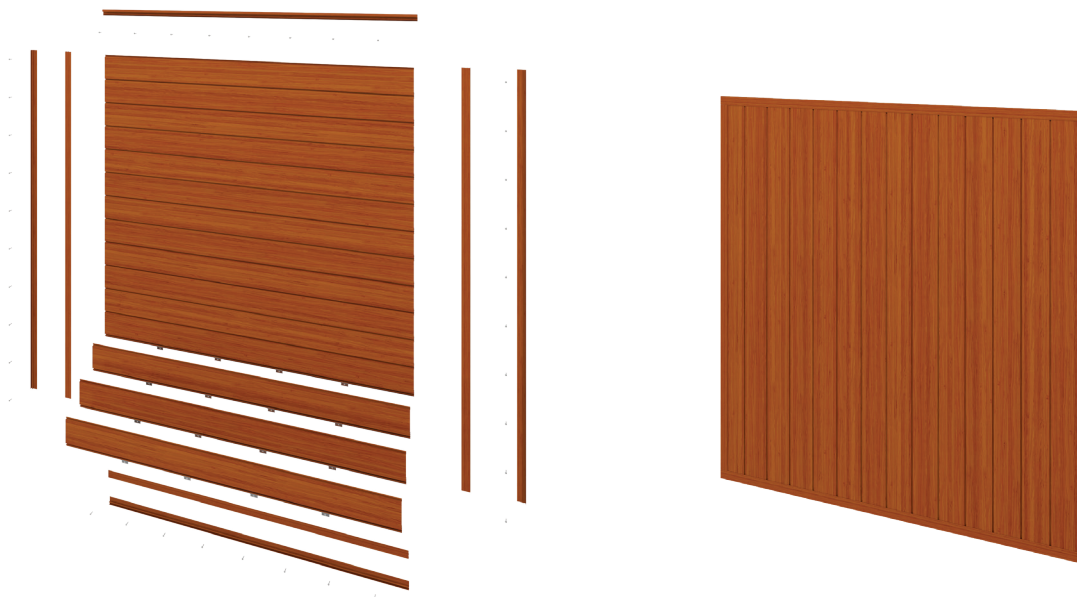



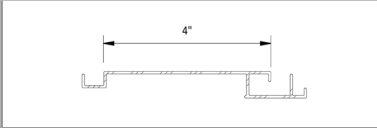

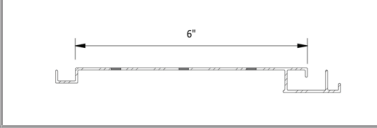

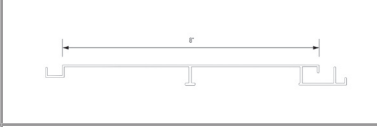
Cut & Fasten (No Pre-Drilling Required)

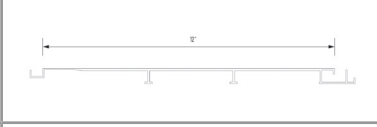
Additional Systems:

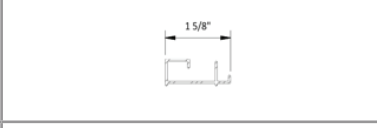
Battens, Fencing, Screening, Gates, Railings, Enclosures, Pergolas

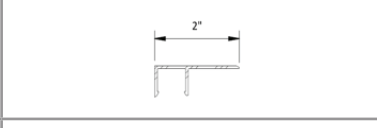
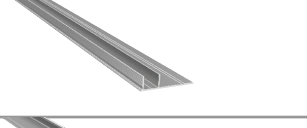
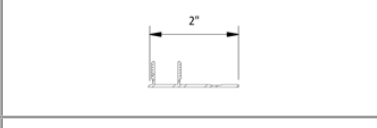
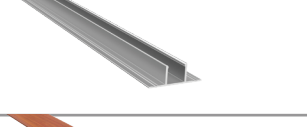
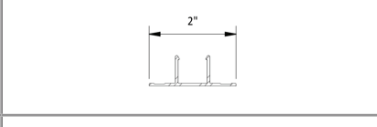

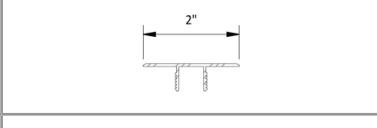

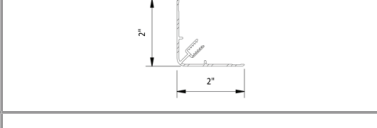
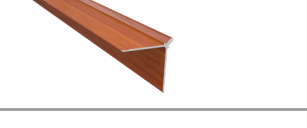
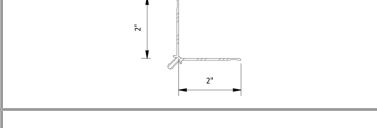
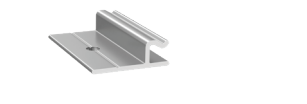
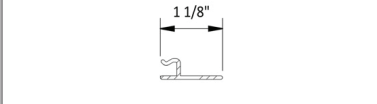
		C-B4	4" Cladding Board 4" x 5/8" x 20'
		C-B6	6" Cladding Board 6" x 5/8" x 20'
		C-B8	8" Cladding Board 8" x 5/8" x 20'
		C-B12	12" Cladding Board 12" x 5/8" x 20'
		C-STR	Cladding Starter Strip 1-5/8" x 5/8" x 20'
		C-TTF	Cladding Termination Trim Top 2" x 2" x 20'
		C-TTM	Cladding Termination Trim Base 2" x 2" x 20'
		C-JTF	Cladding Joint Trim Base 2" x 2" x 20'
		C-JTM	Cladding Joint Trim Top 2" x 2" x 20'
		C-CF	Cladding Corner Female 2" x 2" x 20'
		C-CM	Cladding Corner Male 2" x 2" x 20'
		C-EC	Cladding Clip (Bag of 100) 1-1/8"

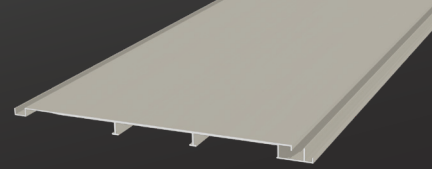

12" CLADDING / SOFFIT PANEL C-B12 STOCK ITEM

General Specifications:

- Imperial Size:**
12" x 5/8" x 20'
- Material Thickness:**
2.38mm
- Applications:**
Cladding / Soffit
- Extrusion Weight:**
31.52 lbs
- Weight per SqFt:**
2.62 lbs
- Extrusion Coverage:**
20' SqFt
- Case Qty:**
31x Panels

Features:

- Assembly:**
Interlocking Cladding/Soffit Panels (Not T&G)
- Install Orientations:**
Horizontal, Vertical, Diagonal, Top-Down or Bottom-Up
- Dimensions:**
20' Standard Production Lengths
- Design:**
Adjustable 3/8" Reveal
32" O.C. Max Fastening Span
- Colors:**
35+ Woodgrain Colors, 10+ Solid Colors
Custom color creation + color matching available

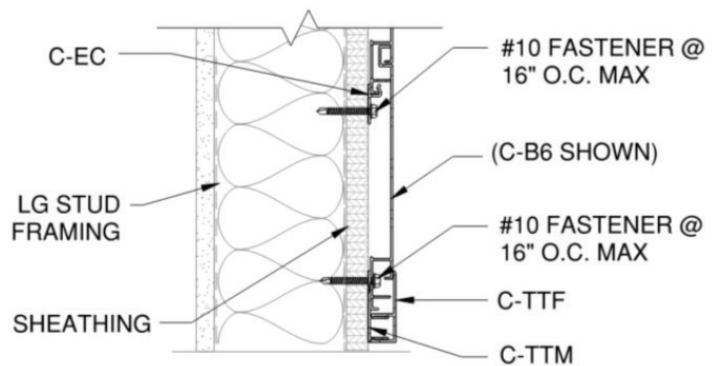
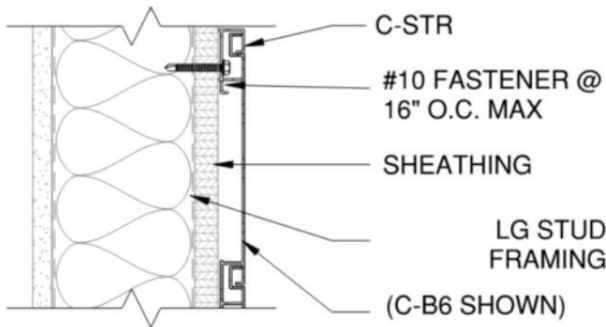
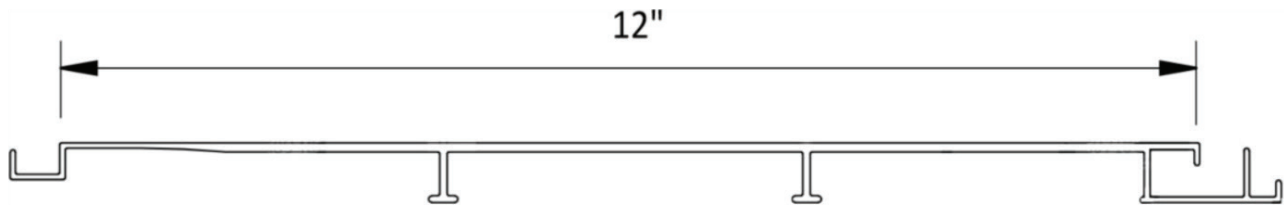

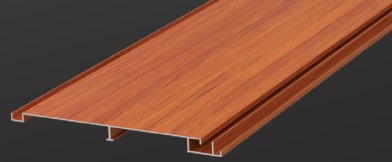

8" CLADDING / SOFFIT PANEL C-B8 STOCK ITEM

General Specifications:

Imperial Size:
 8" x 5/8" x 20'

Material Thickness:
 2.38mm

Applications:
 Cladding / Soffit

Extrusion Weight:
 22.96 lbs

Weight per SqFt:
 1.72 lbs

Extrusion Coverage:
 13.33' SqFt

Case Qty:
 43x Panels

Features:

Assembly:
 Interlocking Cladding/Soffit Panels (Not T&G)

Install Orientations:
 Horizontal, Vertical, Diagonal, Top-Down or Bottom-Up

Dimensions:
 20' Standard Production Lengths

Design:
 Adjustable 3/8" Reveal
 32" O.C. Max Fastening Span

Colors:
 35+ Woodgrain Colors, 10+ Solid Colors
 Custom color creation + color matching available

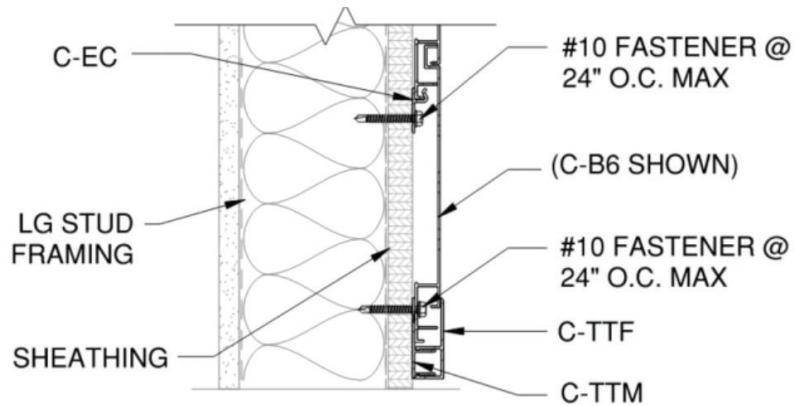
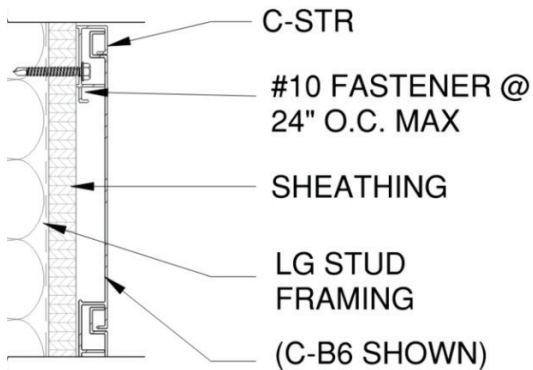
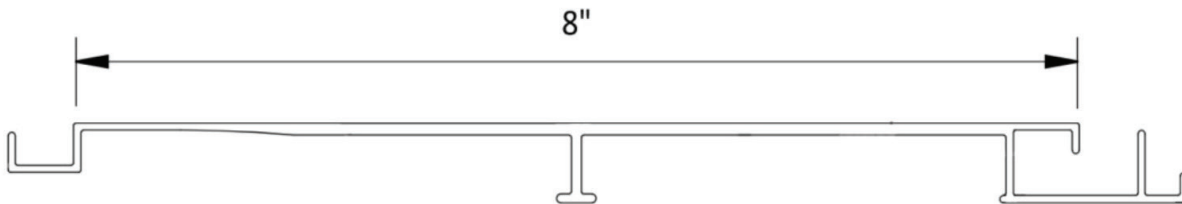

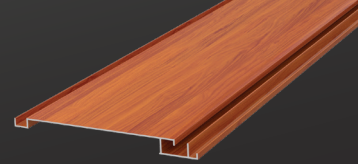

6" CLADDING / SOFFIT PANEL C-B6 STOCK ITEM

General Specifications:

- Imperial Size:**
6" x 5/8" x 20'
- Material Thickness:**
1.4mm
- Applications:**
Cladding / Soffit
- Extrusion Weight:**
10.4 lbs
- Weight per SqFt:**
1.34 lbs
- Extrusion Coverage:**
10' SqFt
- Case Qty:**
50x Panels
- Case SF Coverage:**
500' SF

Features:

- Assembly:**
Interlocking Cladding/Soffit Panels (Not T&G)
- Install Orientations:**
Horizontal, Vertical, Diagonal, Top-Down or Bottom-Up
- Dimensions:**
20' Standard Production Lengths
- Design:**
Adjustable 3/8" Reveal
32" O.C. Max Fastening Span
- Colors:**
35+ Woodgrain Colors, 10+ Solid Colors
Custom color creation + color matching available

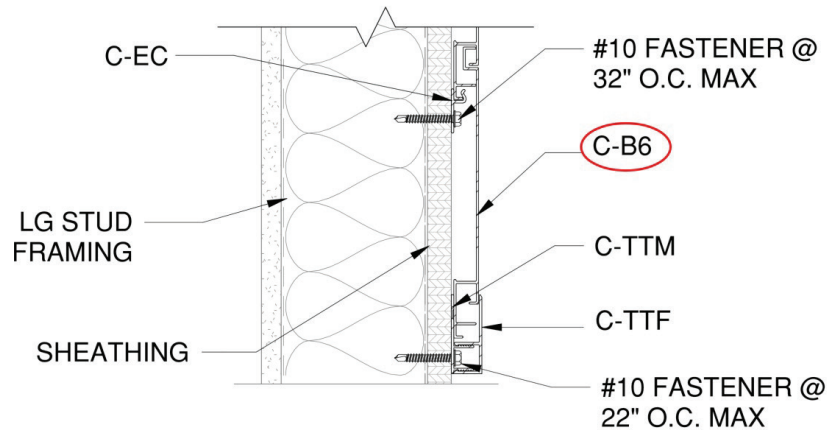
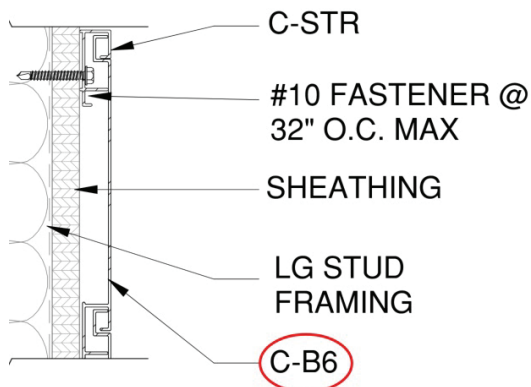
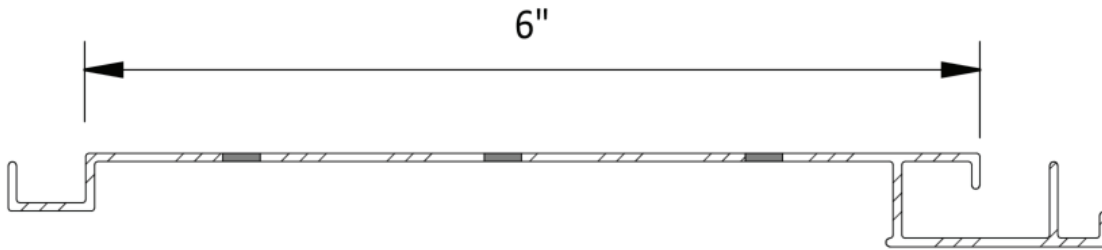



4" CLADDING / SOFFIT PANEL C-B4 STOCK ITEM

General Specifications:

- Imperial Size:**
4" x 5/8" x 20'
- Material Thickness:**
1.4mm
- Applications:**
Cladding / Soffit
- Extrusion Weight:**
10.76 lbs
- Weight per SqFt:**
1.34 lbs
- Extrusion Coverage:**
7.99' SqFt
- Case Qty:**
50x Panels
- Case SF Coverage:**
400' SF

Features:

- Assembly:**
Interlocking Cladding/Soffit Panels (Not T&G)
- Install Orientations:**
Horizontal, Vertical, Diagonal, Top-Down or Bottom-Up
- Dimensions:**
20' Standard Production Lengths
- Design:**
Adjustable 3/8" Reveal
32" O.C. Max Fastening Span
- Colors:**
35+ Woodgrain Colors, 10+ Solid Colors
Custom color creation + color matching available

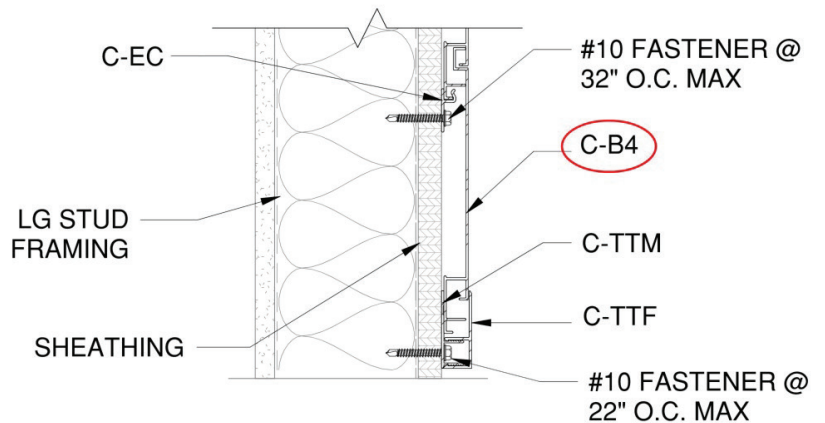
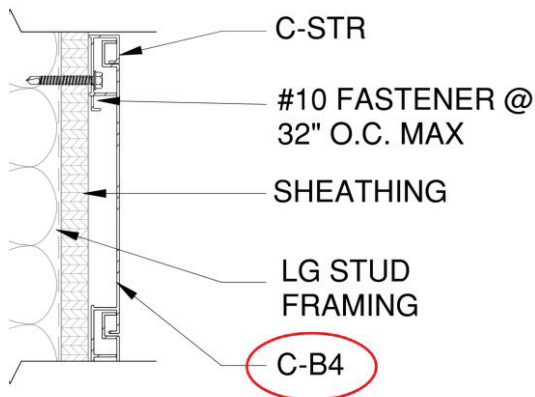
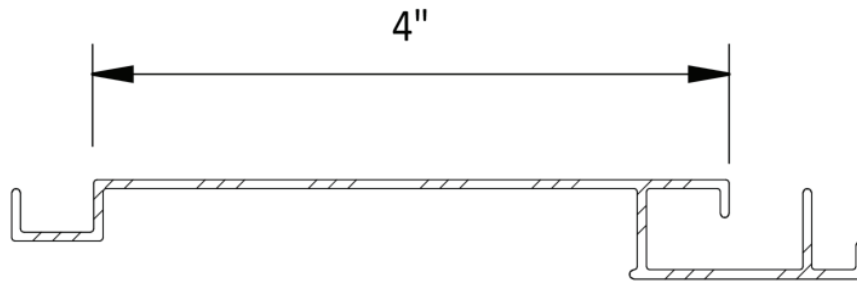

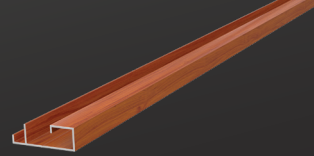

CLADDING STARTER STRIP C-STR STOCK ITEM

General Specifications:

Imperial Size:
1-5/8" x 5/8" x 20'

Material Thickness:
1.8mm

Applications:
Cladding / Soffit

Extrusion Weight:
5 lbs

LF Weight:
0.25 lbs

Case Qty:
100x Pieces

Features:

Assembly:
Interlocking Cladding/Soffit Panels and Trims

Install Orientations:
Horizontal, Vertical, Diagonal

Dimensions:
20' Standard Production Lengths

Design:
22" O.C. Max Fastening Span

Colors:
35+ Woodgrain Colors, 10+ Solid Colors
Custom color creation + color matching available

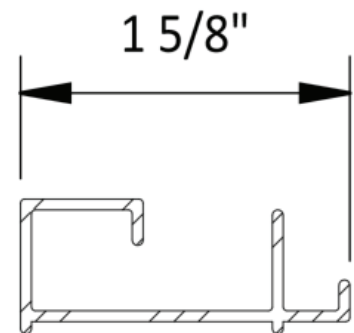
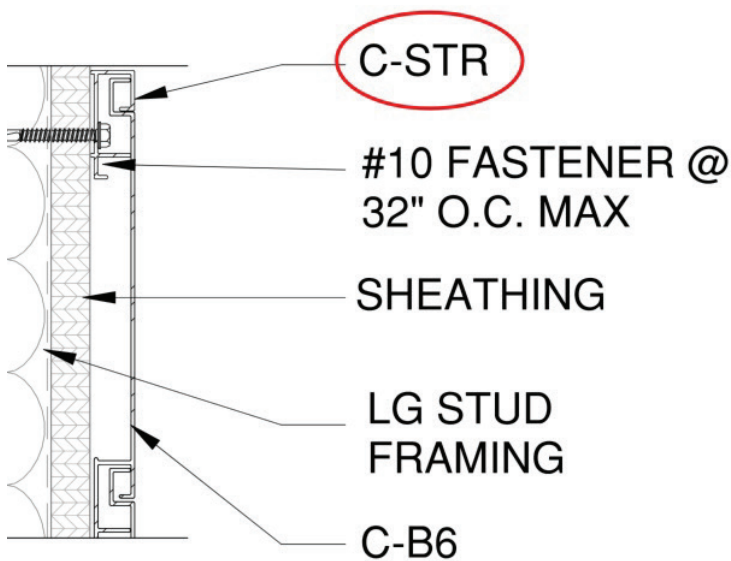

C-STR (Cladding/Soffit Starter Strip) can be concealed within the C-TTF & C-TTM flashing trims.



CLADDING TERMINATION TRIM TOP C-TTF STOCK ITEM

General Specifications:

Imperial Size:

2" x 2" x 20'

Material Thickness:

1.8mm

Applications:

Cladding / Soffit

Extrusion Weight:

5 lbs

LF Weight:

0.25 lbs

Case Qty:

100x Pieces

Features:

Assembly:

Interlocking Cladding/Soffit Panels and Trims

Replaces 'J Channel/Mold'

2-Piece Male + Female Assembly

Install Orientations:

Horizontal, Vertical, Diagonal

Dimensions:

20' Standard Production Lengths

Design:

22" O.C. Max Fastening Span

Colors:

35+ Woodgrain Colors, 10+ Solid Colors

Custom color creation + color matching available

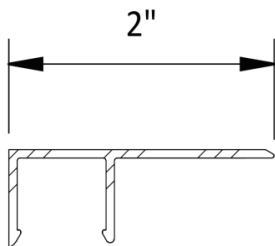

C-TTF (Termination Trim Female) is always used with the C-TTM (Termination Trim Male).

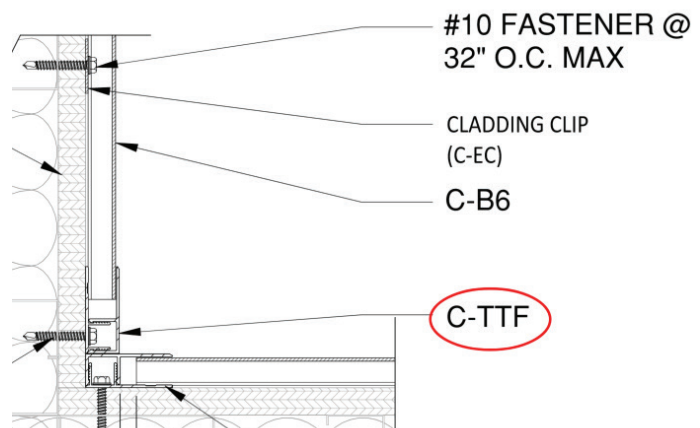
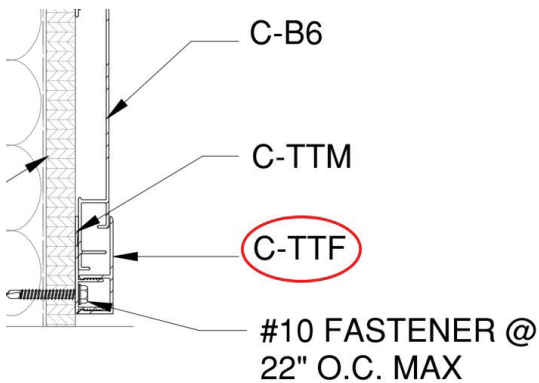
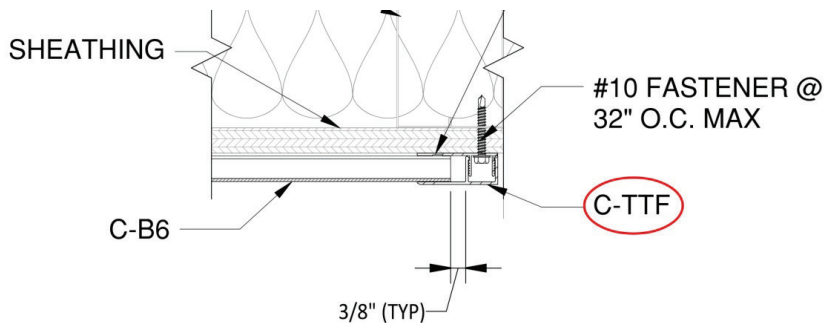

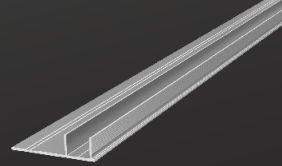

CLADDING TERMINATION TRIM BASE C-TTM STOCK ITEM

General Specifications:

Imperial Size:

2" x 2" x 20'

Material Thickness:

1.8mm

Applications:

Cladding / Soffit

Extrusion Weight:

4.12 lbs

LF Weight:

0.206 lbs

Case Qty:

100x Pieces

Features:

Assembly:

Interlocking Cladding/Soffit Panels and Trims
 Replaces 'J Channel/Mold'
 2-Piece Male + Female Assembly

Install Orientations:

Horizontal, Vertical, Diagonal

Dimensions:

20' Standard Production Lengths

Design:

22" O.C. Max Fastening Span

Colors:

Mill Finish Only

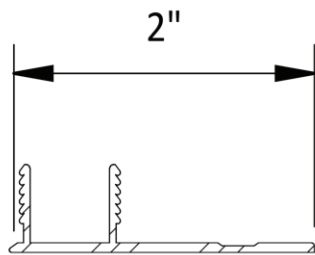

C-TTM (Termination Trim Male) is always used with the C-TTF (Termination Trim Female).

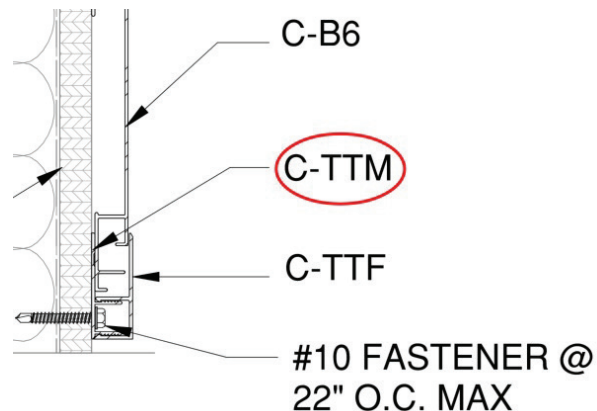
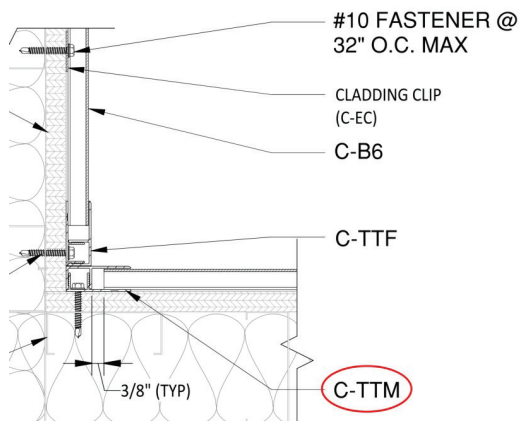
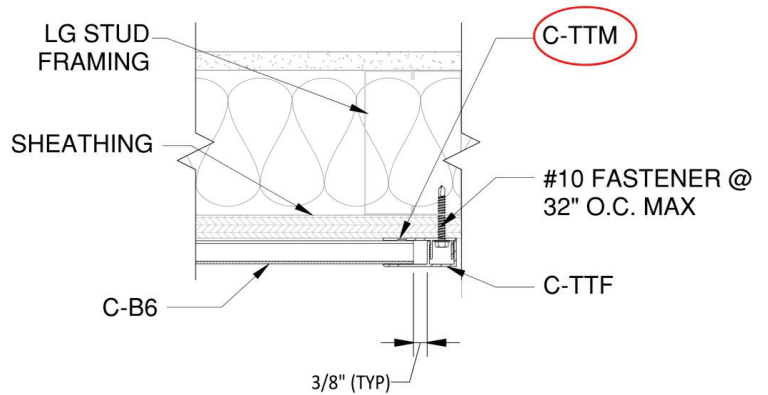

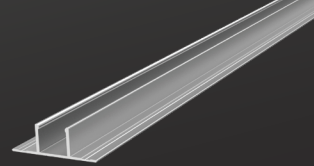

CLADDING JOINT TRIM BASE C-JTF STOCK ITEM

General Specifications:

Imperial Size:

2" x 2" x 20'

Material Thickness:

1.8mm

Applications:

Cladding / Soffit

Extrusion Weight:

4.12 lbs

LF Weight:

0.206 lbs

Case Qty:

100x Pieces

Features:

Assembly:

Interlocking Cladding/Soffit Panels and Trims
Replaces 'H/T Channel/Mold'
2-Piece Male + Female Assembly

Install Orientations:

Horizontal, Vertical, Diagonal

Dimensions:

20' Standard Production Lengths

Design:

22" O.C. Max Fastening Span

Colors:

Mill Finish Only

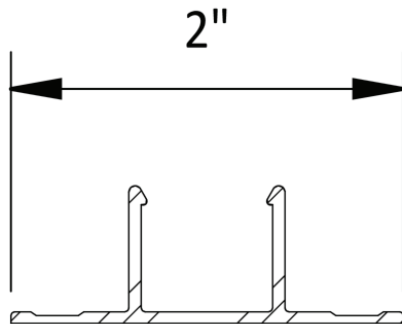

C-JTF (Joiner Trim Female) is always used with the C-JTM (Joiner Trim Male).

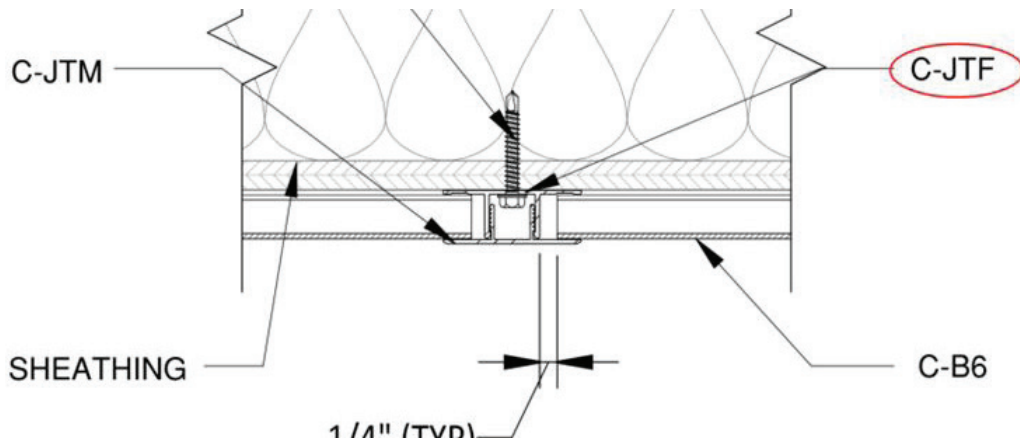

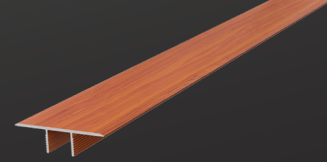

CLADDING JOINT TRIM TOP C-JTM STOCK ITEM

General Specifications:

Imperial Size:

2" x 2" x 20'

Material Thickness:

1.8mm

Applications:

Cladding / Soffit

Extrusion Weight:

4.54 lbs

LF Weight:

0.227 lbs

Case Qty:

100x Pieces

Features:

Assembly:

Interlocking Cladding/Soffit Panels and Trims
Replaces 'H/T Channel/Mold'
2-Piece Male + Female Assembly

Install Orientations:

Horizontal, Vertical, Diagonal

Dimensions:

20' Standard Production Lengths

Design:

22" O.C. Max Fastening Span

Colors:

35+ Woodgrain Colors, 10+ Solid Colors
Custom color creation + color matching available

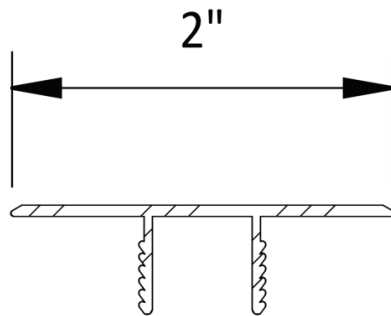

C-JTM (Joiner Trim Male) is always used with the C-JTF (Joiner Trim Female).

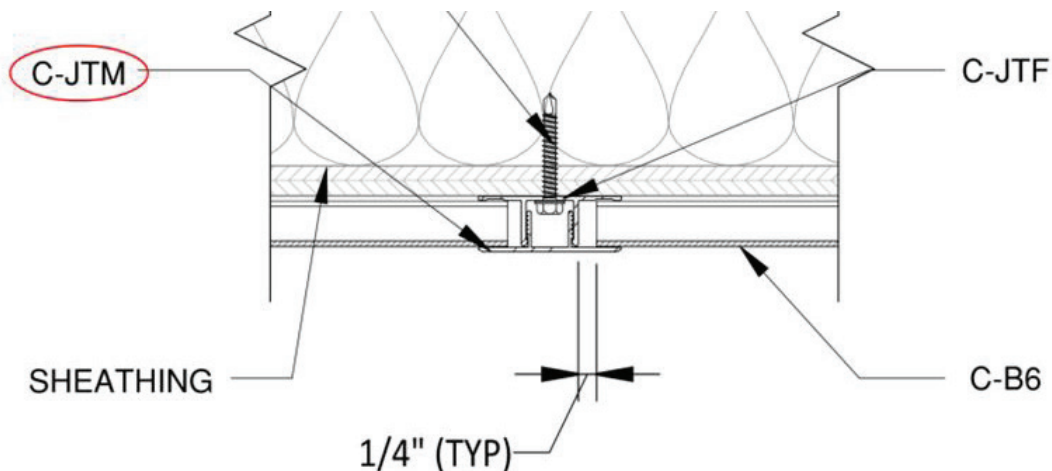

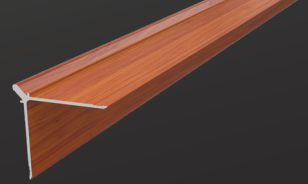

CLADDING CORNER MALE C-CM STOCK ITEM

General Specifications:

Imperial Size:

2" x 2" x 20'

Material Thickness:

1.8mm

Applications:

Cladding / Soffit

Extrusion Weight:

9.28 lbs

LF Weight:

0.464 lbs

Case Qty:

100x Pieces

Features:

Assembly:

Interlocking Cladding/Soffit Panels and Trims
 Replaces 'Corner Mold'
 2-Piece Male + Female Assembly

Install Orientations:

Horizontal, Vertical, Diagonal

Dimensions:

20' Standard Production Lengths

Design:

22" O.C. Max Fastening Span

Colors:

35+ Woodgrain Colors, 10+ Solid Colors
 Custom color creation + color matching available

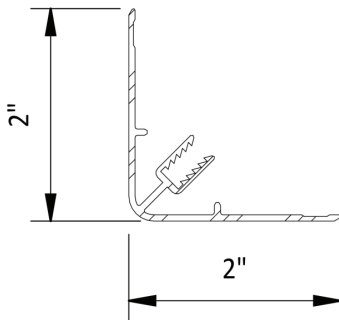

C-CM (Corner Male) is always used with the C-CF (Corner Female).

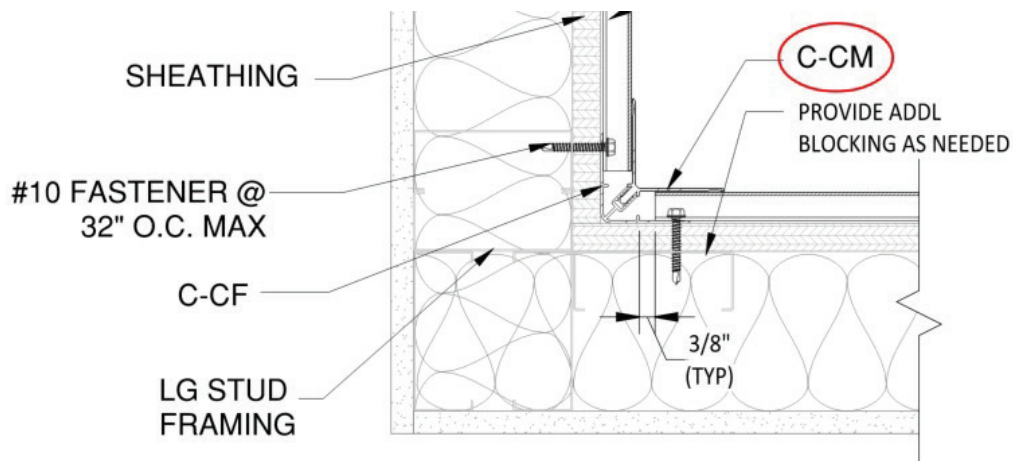
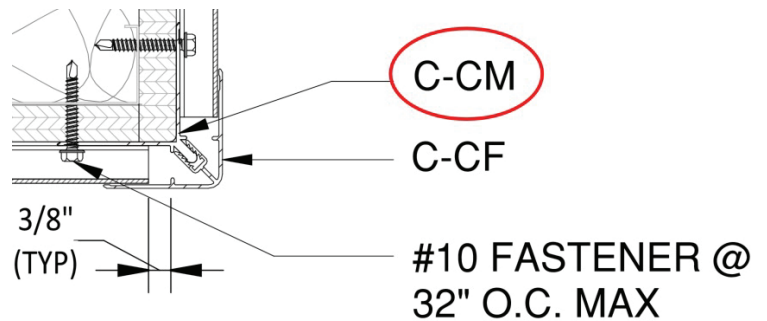

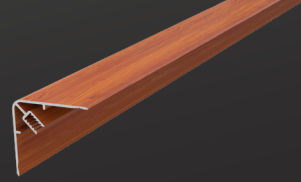

CLADDING CORNER FEMALE C-CF STOCK ITEM

General Specifications:

Imperial Size:

2" x 2" x 20'

Material Thickness:

1.8mm

Applications:

Cladding / Soffit

Extrusion Weight:

7.54 lbs

LF Weight:

0.357 lbs

Case Qty:

100x Pieces

Features:

Assembly:

Interlocking Cladding/Soffit Panels and Trims
 Replaces 'Corner Mold'
 2-Piece Male + Female Assembly

Install Orientations:

Horizontal, Vertical, Diagonal

Dimensions:

20' Standard Production Lengths

Design:

22" O.C. Max Fastening Span

Colors:

35+ Woodgrain Colors, 10+ Solid Colors
 Custom color creation + color matching available

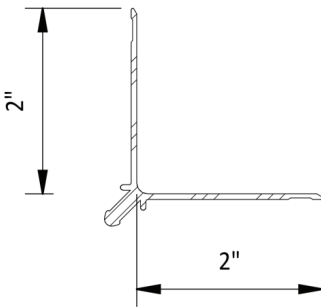

C-CM (Corner Male) is always used with the C-CF (Corner Female).

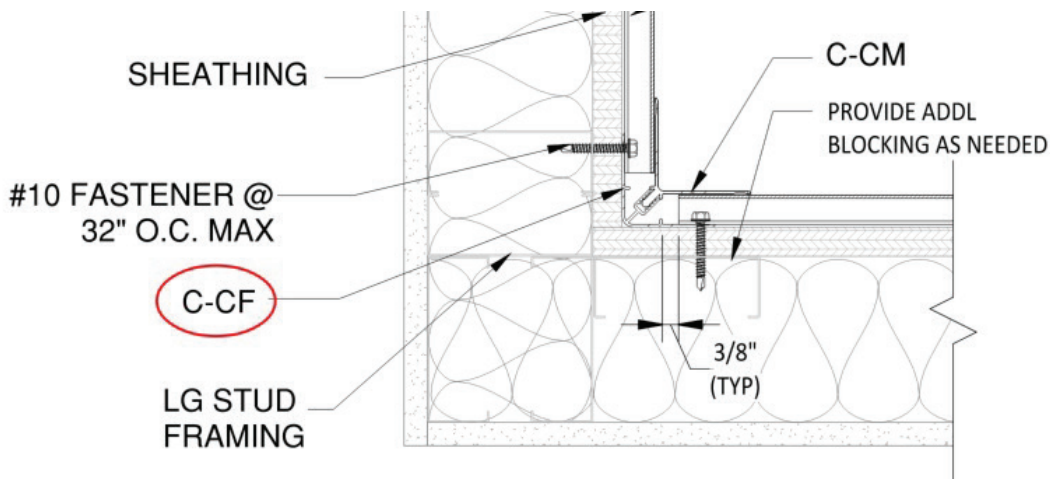
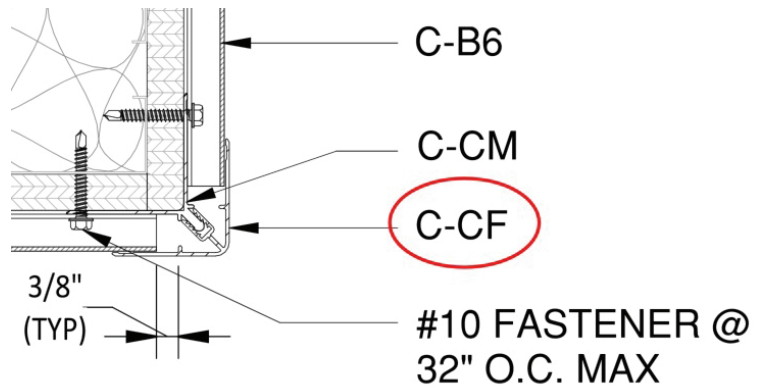

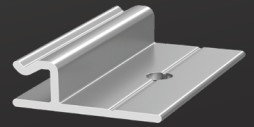

CLADDING CLIP C-EC STOCK ITEM

General Specifications:

Imperial Size:

1" x 3/4"

Material Thickness:

1.4 mm

Applications:

Cladding / Soffit

Case Qty:

Bags of 100 pieces

Features:

Assembly:

Interlocking Cladding/Soffit Panels and Trims

Install Orientations:

Horizontal, Vertical, Diagonal

Dimensions:

20' Standard Production Lengths

Design:

32" O.C. Max Fastening Span

Mitigates thermal expansion

Water management

Colors:

Mill Finish Only

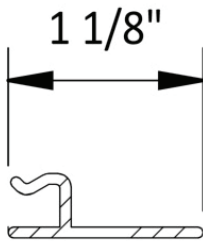

C-EC (Cladding Clip) is always used with the C-B4, C-B6, C-B8, C-B12 (Cladding Boards).

